



Biometric & Keypad Security Door Lock



Parts

Contents	
Parts	3
Additional Tools for Installation	3
Installation Instructions	4
Operation Instructions	13
Parts of The Door Lock	13
Install Batteries	13
Before You Start to Use	14
Change the Master Code	14
Register a User Code	15
Register a Fingerprint	15
Delete Single User Code and Fingerprint	15
Delete All User Codes and Fingerprints	16
Auto-Lock Function	16
Restore to Factory Default Setting	17
Four Ways to Unlock the Door	17
Three Ways to Lock the Door	17
Lock Out Mode	17
Anti-Beep Password Function	18
Temporary Code Function	18
Vacation Mode	19
Sound On & Off	19
Low Battery Status	20
Warranty	21



Front Lock Body



Back Lock Body

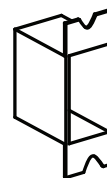

Strike Box

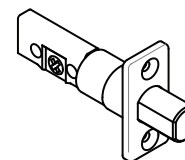

Latch



Keys



Strike Plate



4pcs M4
*8mm screws

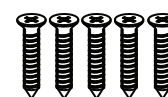

5pcs M5
*14mm self-tapping
screws



6pcs M4
*24mm screws

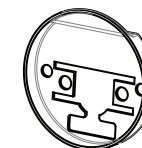

Adaptor Ring

Additional Tools for Installation (Not Included)

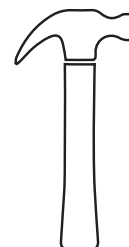

Hammer



Cross Screwdriver

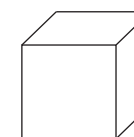

Strike Wood Block

1. Check dimensions

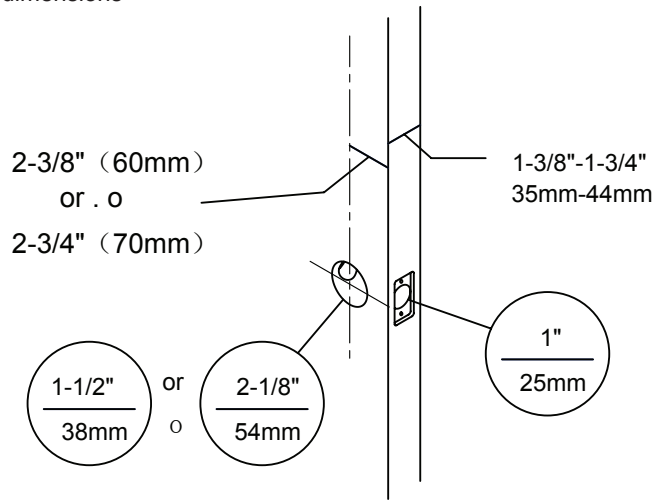

2. Check if the latch works well

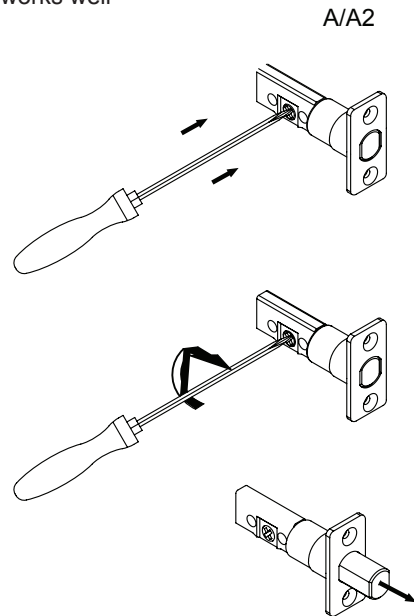

3. Check the position of the front installation hole

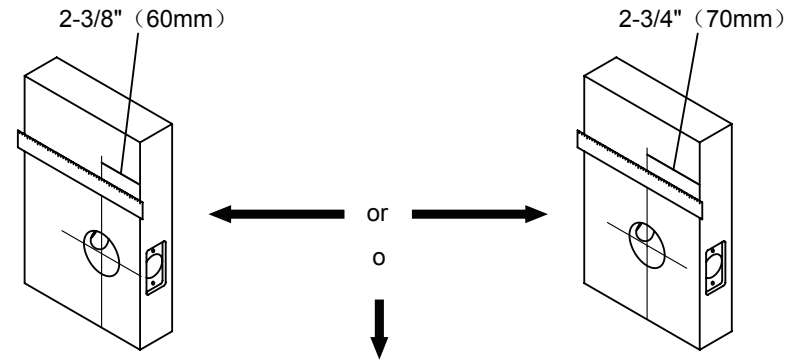

Pre-set drive-in latch is 60mm
Adjust the latch to 70mm as below if needed

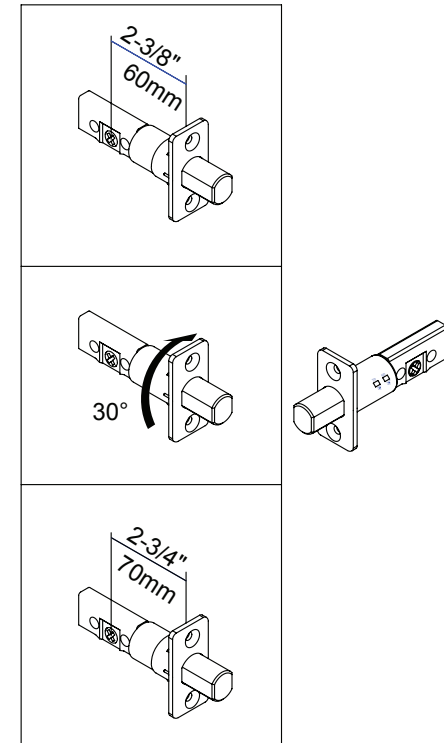

4. Check the size of the side installation hole

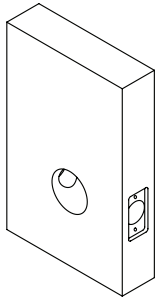

Insert the latch to the side hole
(Please follow the "up" direction)

Fix the bold with 2pcs self-tapping screws

M5*14mm
Self-Tapping
Screws x 2

Check the latch function
with a screwdriver

5. Check the size of the front installation hole

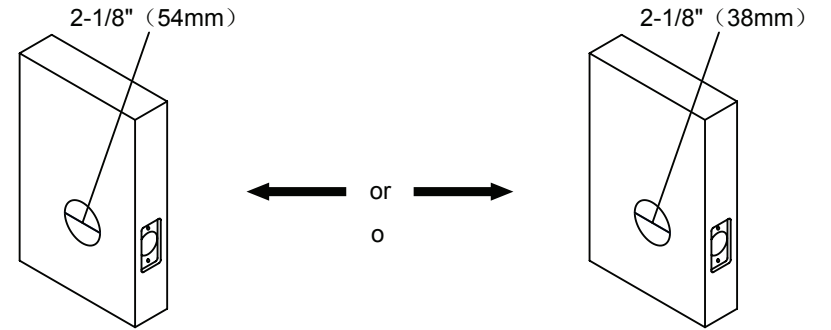

2-1/8"
54mm

1-1/2"
38mm

6.

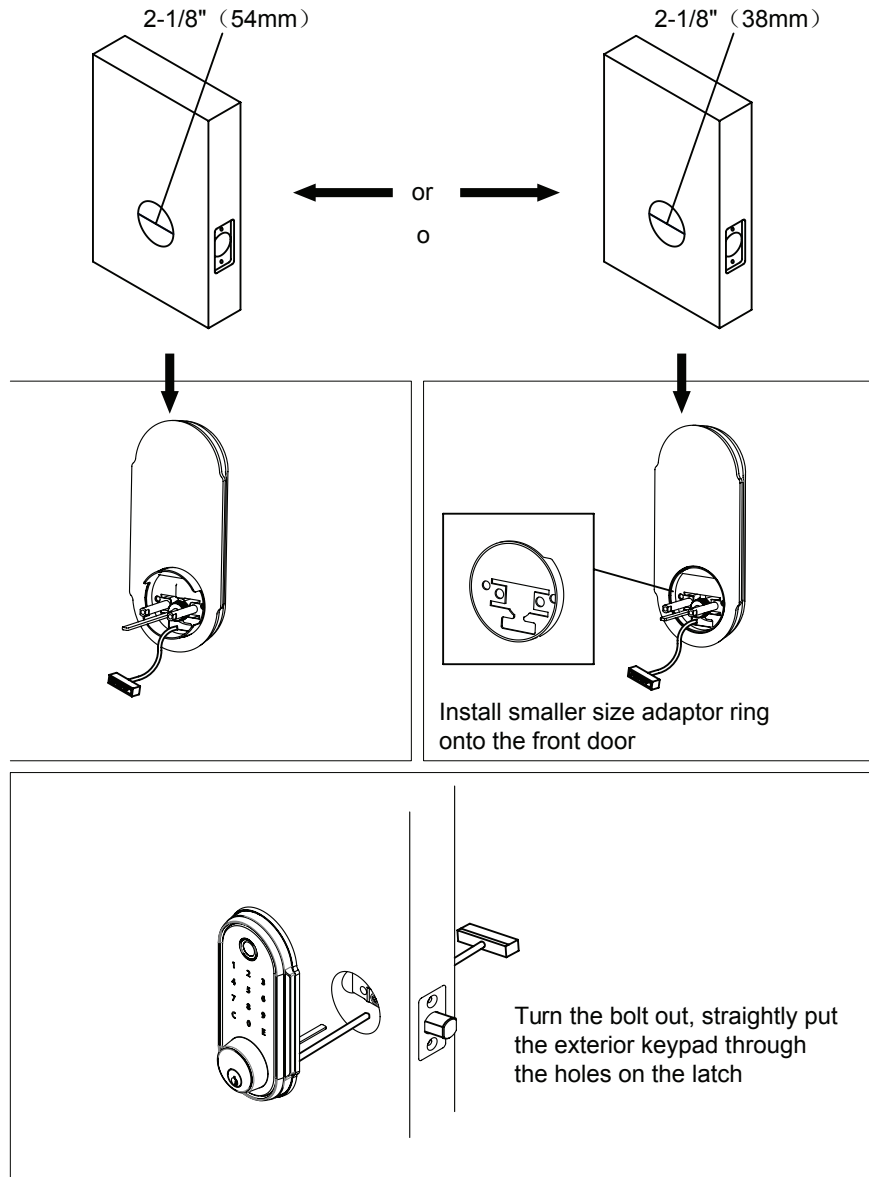

7.

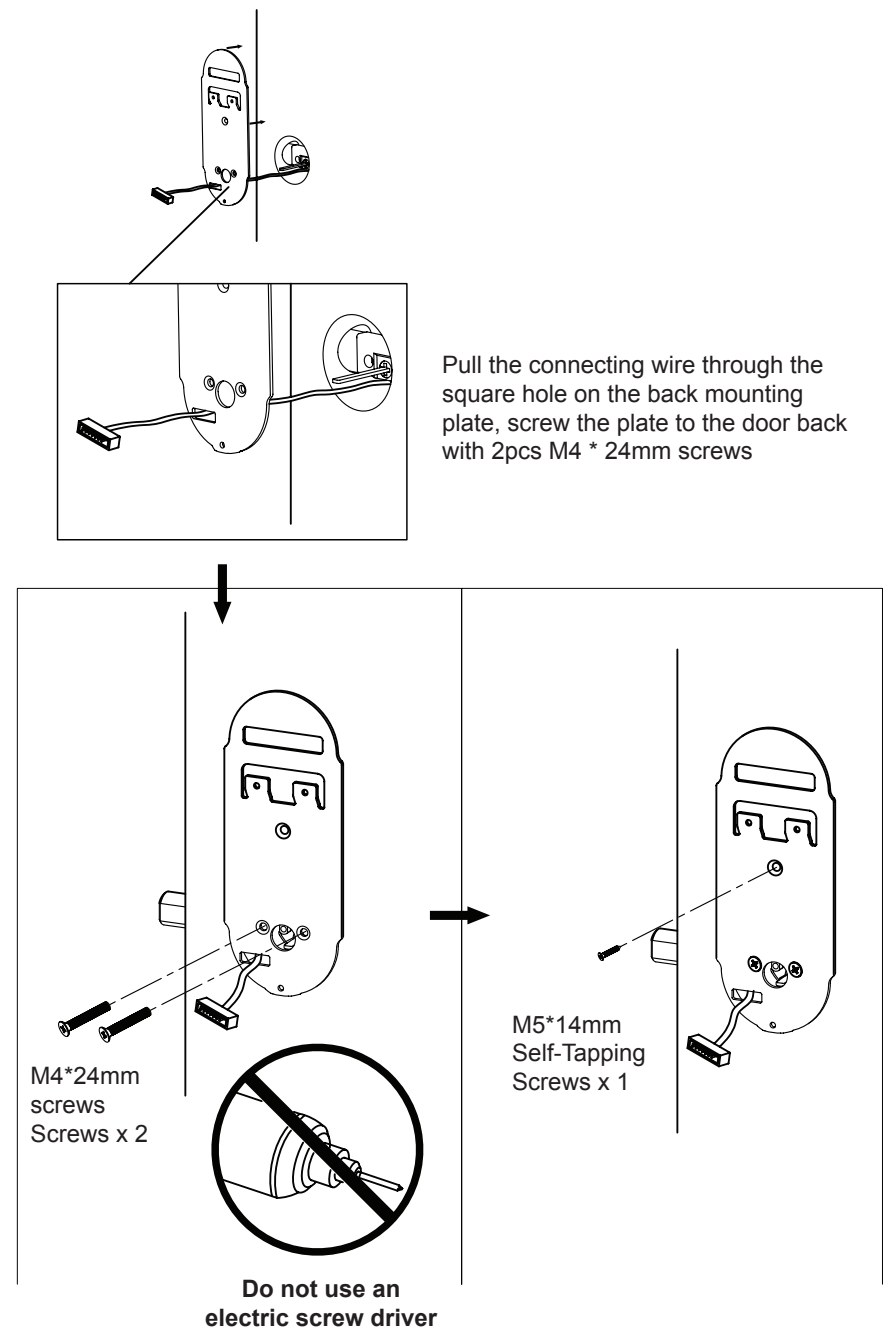

8.

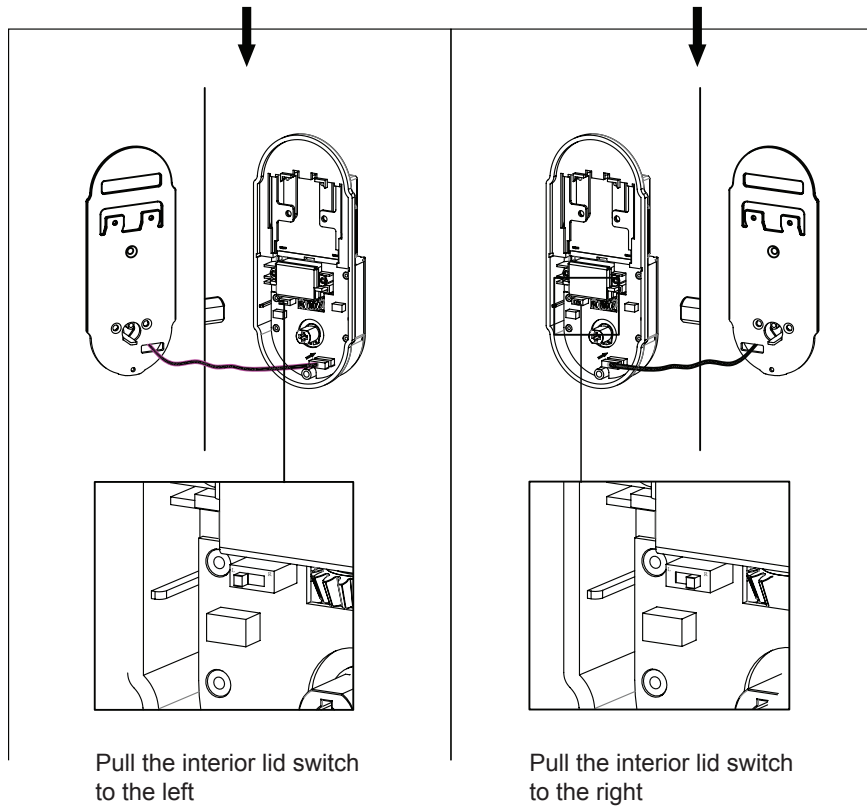
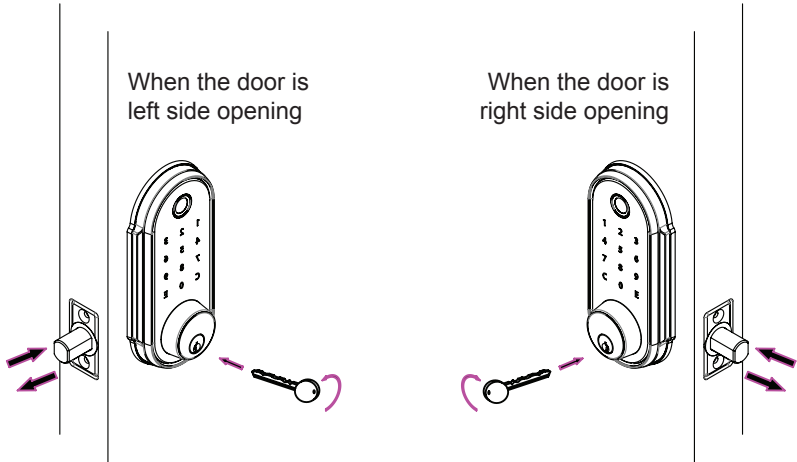

Pull the interior lid switch to the left

Pull the interior lid switch to the right

9. Inset the connecting wire to the cable on the interior lid

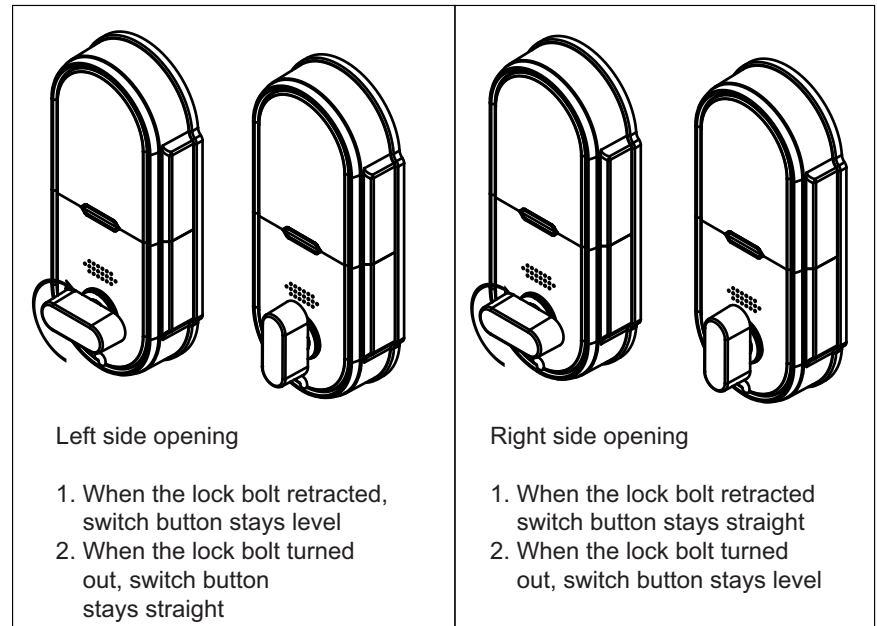
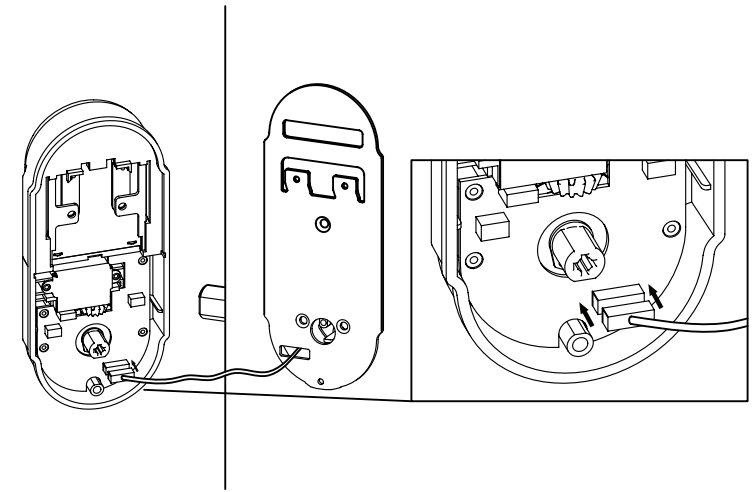

Left side opening

1. When the lock bolt retracted, switch button stays level
2. When the lock bolt turned out, switch button stays straight

Right side opening

1. When the lock bolt retracted switch button stays straight
2. When the lock bolt turned out, switch button stays level

10. Install the battery

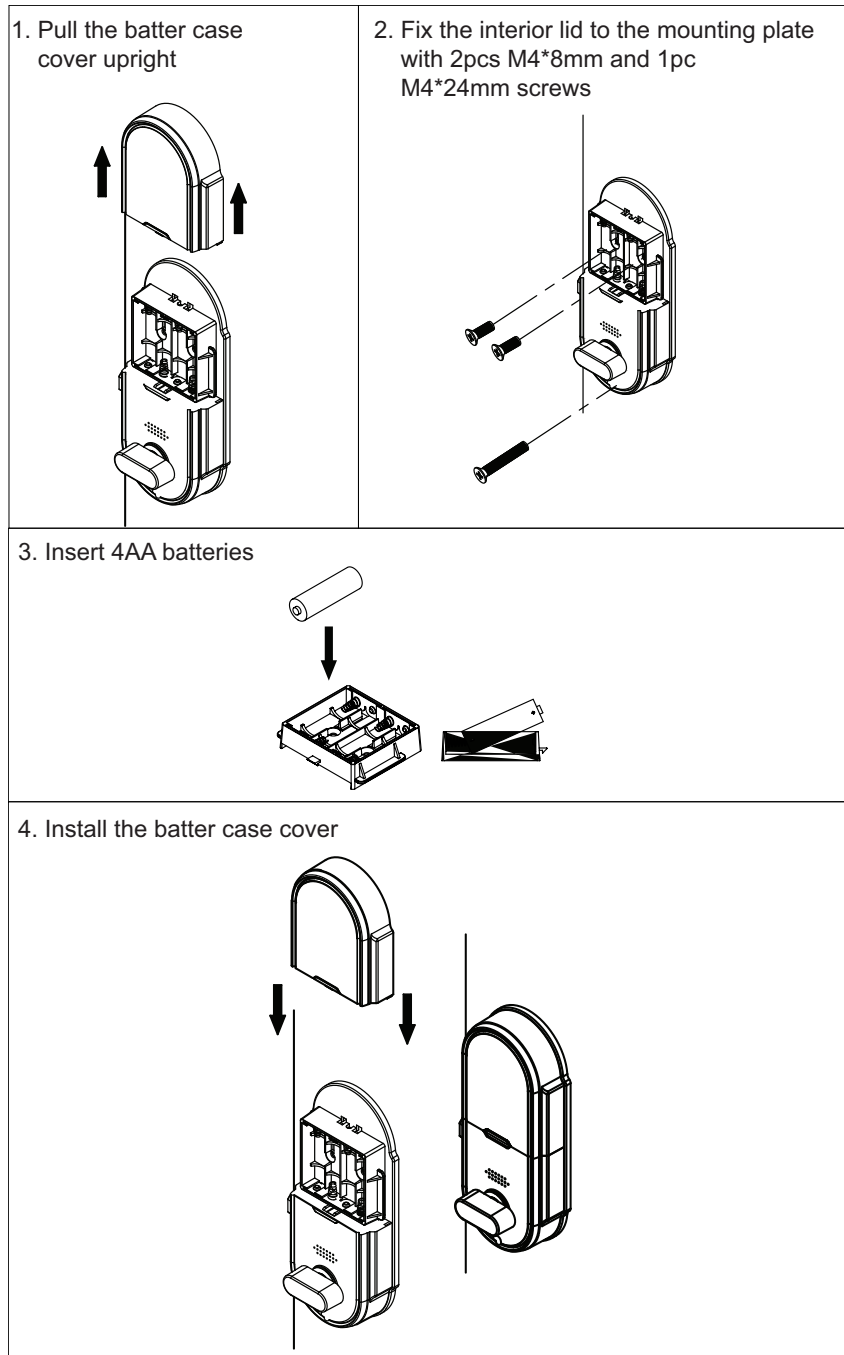

Operation Instructions

* Please read all instructions before using this door lock

1. New door lock is in factory default mode: No fingerprint can open the door lock and Default Master Code is 123456. Under factory default mode, you can use default master code to open the lock.
2. For security purposes, change the default master code as soon as possible.
3. Door lock can be opened by fingerprint, user code, master code, or emergency keys.
4. Register fingerprints and PIN codes and test a few times before closing the door.
5. Test door lock functions before installing onto door.
6. Test with a non-registered fingerprint and non-registered user code to make sure that the registrations are successfully.
7. **Test the keys and store them in proper place in case power off or malfunction situation.**

Parts of The Door Lock



- A. Fingerprint Scanner & Indicator Lights
- B. Keypad
- C. Emergency Key Access
- D. Battery Cover
- E. Battery Cover Button
- F. Knob

Install Batteries

1. Require 4 new Alkaline AA batteries (not included)
2. Press in the battery cover button and gently lift the battery cover to expose the battery compartment.

3. Insert 4 new Alkaline AA batteries into the battery compartment and pay attention to the polarity of the batteries.
4. Gently place the battery cover back into place

NOTE:

- Do not mix old and new batteries.

Before You Start to Use

1. The lock retains one master code and 50 user codes (50 user IDs).
2. The lock includes 50 user IDs (1-50). Each ID contains a single user's code & a single fingerprint (you can set one user code & one fingerprint for each ID or set either one user code or one fingerprint for each ID. Don't need to set both to get the access.) Each user code must be set with 4-8 digits.
*If the ID has registered before, register to the same ID will override the previous user's code and fingerprint.
3. The lock is with automatic deadbolt. Please use it with latching handle which can fix the deadbolt in right position to avoid the door can't open/close properly.
4. Use the key to check if the locking mechanism works well.
5. Try to use factory default master code to unlock the door; test if the auto-lock feature works well. (Please refer to the section of Auto-Lock feature for setting up.)
6. The lock is powered by 4 AA batteries (not included) that can last up to 8 months depending on usage. We suggest the users check the battery status and replace with new batteries every six months.

Use factory default master code to unlock the safe

- Factory Default Master Code: 123456
- Touch the screen to activate the keypad.
- Press and HOLD "E" for 3 seconds and you will hear one beep.
- Input "123456" and confirm by press "E"; after three short beeps are heard, the door will open automatically.

NOTE:

- Please change the factory default master code to your owns after the first usage.

Change the Master Code

1. Touch the screen to activate the keypad.
2. Input the current master code, confirm by press "E" and will hear three short beeps.
3. Press "4", confirm by press "E" and will hear three short beeps.
4. Enter a new master code (4-8 digits), confirm by press "E" and will hear three short beeps.
5. Re-enter the new master code again, confirm by press "E" and will hear three short beeps.

6. A new master code is set successfully.

*** Faulty operation will cause five long beeps. Please set it by following above steps again.**

Register a User Code

1. Touch the screen to activate the keypad.
2. Input the master code, confirm by press "E" and will hear three short beeps.
3. Press "1", confirm by press "E" and will hear three short beeps.
4. Press User ID (ID: 1-50), confirm by press "E" and will hear three short beeps.
5. Enter a new user's code (4-8 digits), confirm by press "E". Three short beeps will be heard and the light of keypad keeps on.
6. Re-enter the new user code, confirm by press "E".
7. Keypad will beep three times shortly and the light of keypad will disappear. A new user code is registered successfully.

*** Faulty operation will cause five long beeps. Please restart from the first step of this section.**

*** If the ID has registered before, register to the same ID will override the previous user's code.**

Register a Fingerprint

1. Touch the screen to activate the keypad.
2. Input the master code, confirm by press "E" and will hear three short beeps.
3. Press "1", confirm by press "E" and will hear three short beeps.
4. Press User ID (ID: 1-50), confirm by press "E" and will hear three short beeps.
5. The blue light around the fingerprint scanner stays on.
6. Put your finger on the fingerprint scanner, a single beep stands for one time successful setting of the fingerprint. After a single beep is heard, please release your finger; repeat 6 times. (When you put your fingerprint on scanner each time, please slightly change the position of your finger. Therefore, the system will have a full image of your finger after you repeat this step 6 times).

A user's fingerprint is registered successfully after three short beeps and the light will turn to green.

*** Faulty operation will cause five long beeps. Please restart from the first step of this section.**

*** If the ID has registered before, register to the same ID will override the previous user's fingerprint.**

Delete Single User Code and Fingerprint

1. Touch the screen to activate the keypad.
2. Input the master code, confirm by press "E" and will hear three short beeps.
3. Press "2", confirm by press "E" and will hear three short beeps.
4. Enter the specific User ID (ID: 1-50) you would like to delete, confirm by press

“E”. Three short beeps will be heard and the light of keypad keeps on.

5. Re-enter the ID, confirm by press “E”. Keypad beeps three times shortly and the light of keypad will disappear. The user’s code and fingerprint of a specific ID No. is deleted successfully.

*** Faulty operation will cause five long beeps. Please restart from the first step of this section.**

Delete All User Codes and Fingerprints

1. Touch the screen to activate the keypad.
2. Input the master code, confirm by press “E” and will hear three short beeps.
3. Press “3”, confirm by press “E”. Three short beeps will be heard and the light of keypad keeps on.
4. Re-enter the master code and confirmed by “E”.
5. Keypad beeps three times shortly and the light of keypad will disappear. All users’ codes and fingerprints are deleted successfully.

*** Faulty operation will cause five long beeps. Please restart from the first step of this section.**

*** Please consider carefully before doing this operation. Once this operation is conducted, all codes will be deleted & could not be reverted.**

Auto-Lock Function

Door lock will be auto-locked after the time you set up.

Turn on the Auto-Lock Function

1. Touch the screen to activate the keypad.
2. Enter master code and confirmed by “E” and will hear three short beeps.
3. Press “5”, confirm by press “E” and will hear three short beeps.
4. Enter “Your Desired Auto-Lock Time” (you can set up from 5-900 seconds), and confirmed by “E”.

*For example, if you want to set up Auto-Lock function in 20 seconds, enter “20” and confirmed by “E”.

5. Keypad beeps three times shortly; the auto locking has set successfully

Turn off the Auto-Lock Function

Door lock will not be auto-locked once you turn off this function. Please make sure that you lock the door while you are leaving.

1. Touch the screen to activate the keypad.
2. Enter master code and confirmed by “E” and will hear three short beeps.
3. Press “5”, confirm by press “E” and will hear three short beeps.
4. Enter “00”, and confirmed by “E”.
5. Keypad beeps three times shortly; the auto locking has turned off successfully.

*** Faulty operation will cause five long beeps. Please enter the codes to set it by above steps again.**

Restore to Factory Default Setting

1. Take out all batteries; touch the keypad screen for electric discharging.
2. Install all batteries after 10 seconds and will hear two short beep
3. Within 2 seconds, press “C” three times
4. Keypad beeps three times shortly and the lock is restored to factory default setting (all users’ code and fingerprint codes will be deleted at the meantime)

Four Ways to Unlock the Door

1. Open the lock with master code:
 - Touch the screen to activate the keypad.
 - Press and HOLD “E” for 3 seconds and you will hear one beep.
 - Input the master code and confirm by press “E”; after the short three beeps, the lock will open automatically.
2. Open the lock with user code:
 - Touch the screen to activate the keypad.
 - Enter a user’s code and confirmed by “E”. Lock opens after three short beeps.
3. Open the lock with fingerprint:
 - Put a registered fingerprint on fingerprint scanner. Once the scanner accepts the fingerprint, the indicator light will turn green and the lock will open after three short beeps.
4. Use an override key:
 - Insert the override key; turn counter clockwise to unlock the door.

*** Faulty operation will cause five long beeps. Please try it again.**

Three Ways to Lock the Door

1. When you are inside of the house, turn the door lock knob at the back door to lock the door.
2. When you are outside of the house, touch the screen to activate the keypad and press “E”. The locking bolt will automatically pull out and one short beep will be heard. Please re-check if the door is locked.
3. Set the Auto-Lock function to lock the door. Please refer to the instruction within Auto-Lock section.

*** Please make sure that your door is locked while you are leaving.**

Lock Out Mode

1. Entry the wrong code consecutively for 3 times, the keypad will shut down for 15 seconds; 3 times more wrong entries will shut down the keypad 1 minutes; 3 times wrong entries again will shut down the keypad for 15 minutes. While shutting down, even a correct code won’t open the door; only an override key can unlock the door.

2. Entry the wrong fingerprint code consecutively for 6 times, the keypad will shut down for 15 seconds; 6 times more wrong entries will shut down the keypad 1 minutes; 6 times wrong entries again will shut down the keypad 15 minutes. While shutting down, even a correct code won't open the door; only an override key can unlock the door.

- * **During the lock-out duration, the alarm will keep on.**
- * **While shutting down, any touch on the keypad will cause faulty operation of five long beeps.**
- * **Remove the batteries will release the keypad from shutting down mode.**

Anti-Beep Password Function

Barska's Biometric & Keypad Security Door Lock has Anti-Beep Password Function which could effectively avoid code spying while others are surrounding.

- Random Numbers + Correct User Code or Master Code + Random Numbers (Within 30 Digits)

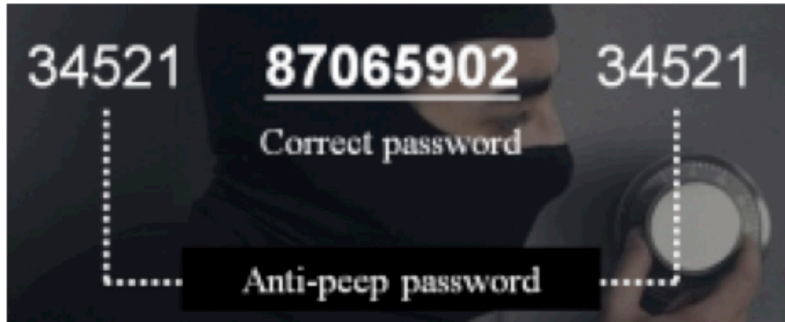

- There will be three short beeps and door will open after the correct code is entered.

- * **Master code also has anti-beep password function. Users can use this function when they use master codes to unlock the door or do other operations.**

Temporary Code Function

A temporary code will be helpful if there is a friend stops by or housekeeping service needs to get into your house while you are not at home. (The temporary code can be used only once.)

1. Touch the screen to activate the keypad.
2. Enter master code and confirmed by "E" and will hear three short beeps.
3. Press "8", confirm by press "E" and will hear three short beeps.
4. Enter the temporary code (4 – 8 digits) and confirmed by "E". Three short beeps will be heard and the light of keypad keeps on.
5. Re-enter the temporary code and confirmed by "E".

6. Keypad beeps three times shortly and the light of keypad will disappear. A single-use code has been set successfully.

- * **Faulty operation will cause five long beeps. Please restart from the first step of this section.**

Vacation Mode

Under the vacation mode, the door can be unlocked only by master code or an override key. This mode is suitable for office & commercial management during vacation.

1. Turn on vacation mode:
 - Touch the screen to activate the keypad.
 - Enter master code and confirmed by "E" and will hear three short beeps.
 - Press "10", confirm by press "E". Three short beeps will be heard and the light of keypad keeps on.
 - Press "1", confirm by press "E".
 - Keypad beeps three shortly and the light of keypad will disappear, vacation mode has been turned on.

- * **Once the lock has been opened by master code, the vacation mode will be turned off automatically.**

2. Turn off vacation mode:
 - Touch the screen to activate the keypad.
 - Press & hold "E" for 3 seconds and will hear one beep.
 - Enter master code and confirmed by "E".
 - Keypad beeps three times shortly. The lock has been opened and vacation mode has been turned off.

- * **Faulty operation will cause five long beeps. Please restart from the first step of this section.**

Sound On & Off

1. Turn on the sound: (Sound is turned on in factory default setting)
 - Touch the screen to activate the keypad.
 - Enter master code and confirmed by "E" and will hear three short beeps.
 - Press "6", confirm by press "E". Three short beeps will be heard and the light of keypad keeps on.
 - Press "2", confirm by press "E".
 - Keypad beeps three shortly and the light of keypad will disappear, sound has been turned on.

2. Turn off the sound: (No alarm system)
 - Touch the screen to activate the keypad.
 - Enter master code and confirmed by "E" and will hear three short beeps.
 - Press "6", confirm by press "E". Three short beeps will be heard and the light of keypad keeps on.



- Press "1", confirm by press "E".
- Keypad beeps three shortly and the light of keypad will disappear, sound has been turned off.

*** Faulty operation will cause five long beeps. Please restart from the first step of this section.**

Low Battery Status

1. When the lock is in low battery, the light around the fingerprint scanner turns red (normally it shows green); the keypad will also beep 10 times after opening.
2. In low battery condition, touching the keypad will cause four beeps. Please replace the new batteries as soon as possible.



1 YEAR LIMITED WARRANTY

Biometric & Keypad Security Door Lock

BARSKA® Optics, as manufacturer, warrants this new product to be free of original defects in materials and/or workmanship for the length of time specified by this warranty. This warranty does not include damage caused by abuse, improper handling, installation, maintenance, normal wear-and-tear, unauthorized repairs or modifications and tampering in anyway.

This warranty is limited to the original purchaser and is not transferable. This warranty applies only to products purchased in the United States of America.

In the event of a defect within 30 days, the consumer must return the defective unit to the BARSKA dealer (the place of purchase) at his/her own expense.

Beyond 30 days, BARSKA products should be sent to the following address for warranty repairs. Products must be packed carefully and sturdily to prevent damage in transit, and returned freight prepaid to:

BARSKA® OPTICS
 Repair Department
 855 Towne Center Drive
 Pomona, CA 91767

For additional and updated information please visit our website at www.barska.com Please email info@barska.com or call 1-888-666-6769 for Return Merchandise Number (RMA#) before any returns.

NOTE: All merchandise received without a valid RMA # will be returned to shipper at his/her own expense.

Please include all of the following when returning BARSKA products for service and/or replacement:

1. Please write your complete details (Name, Address, Telephone #, E-mail address, RMA#, etc.)
 2. Purchase receipt or Proof of Purchase. (Original/Copy)
 3. A brief explanation of the defect.
 4. A Check/Money Order of \$40.00 to cover inspection, shipping and handling.
- *Please allow 6-8 weeks for delivery.

This product will either be replaced or repaired at the discretion of the warrantor. If it's a discontinued item, we will replace the product with an equivalent product. Should the repair not be covered by this warranty, an estimate will be sent for your approval. Non-warranty repairs or refurbishing of your products are always provided at a reasonable cost.

BARSKA® Optics shall not be liable for any consequential, incidental and/or contingent damages whatsoever. We will not pay shipping, insurance or transportation charges from you to us, or any import fees, duties and or taxes. This warranty supersedes all previous BARSKA® Optics warranties.