



User Manual Pistol Keypad Safe

Read all instructions before using this safe.

WARNING

- Avoid leaving door open and unattended; it will allow unauthorized individuals to reprogram the safe, gaining full access to the safe and contents.
- Store emergency keys in a secure place; NOT inside of the safe.
- Be aware of the load bearing. Failure to do so can result in personal injury and/or damage to property. Use appropriate tools when performing work and always use eye protection.
- When mounting the safe make sure the compartment has enough space to drop open. The compartment requires gravity to fully release, always install in a vertical position.
- Keep safe away from children.

NOTE: BARSKA is not responsible if the safe or its contents gets lost or stolen

Parts

- A. Mounting Bracket
- B. Indicator Light
- C. Key Pad
- D. Key Access
- E. Initialization Button
- F. Battery Compartment
- G. Mounting Area

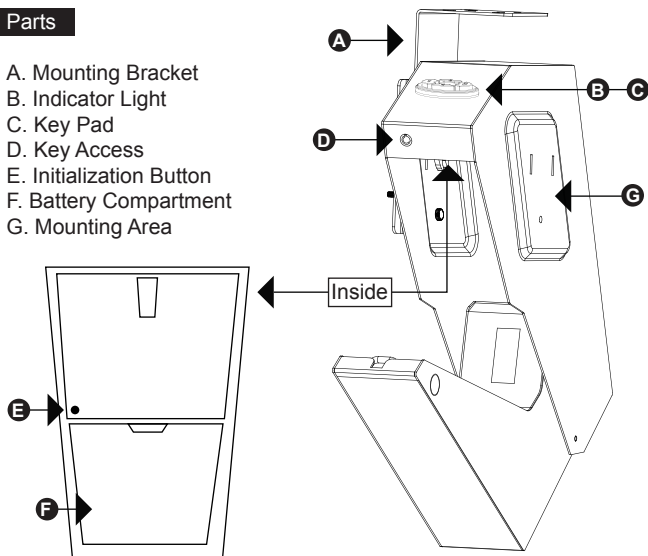

Start

Open pistol safe with emergency keys and install 4 AA batteries. Pay attention to the polarity of the batteries.

Note: Do not mix new and old batteries.

Register Pin Code

Press and hold the initialization button inside the safe until light on keypad come on and two beeps heard.

Enter in desired Pin Code(4-6 digits) and press initialization button again when finished. Then, Pin Code is registered successfully.

NOTE: Default Pin Code is 1234. Once the Pin Code has been registered with new Pin Code, the default Pin Code will be replaced.

Open

Press set pin code and safe should open

Sound Option

Sound On/Off

Press and hold 4 button until light is seen to turn the sound for the safe on/off.

Mounting

- a. Mounting Bracket Hole
- b. Thumb Screw Hole
- c. Wall Mounting Hole

Mounting Holes Of The Safe

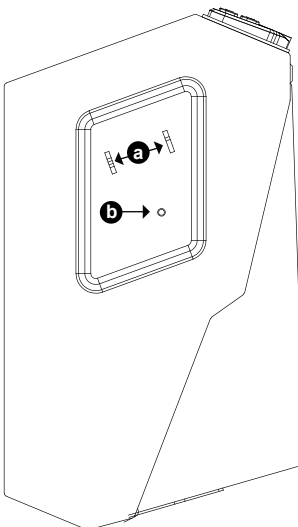

Mounting Holes Of The Mounting Bracket

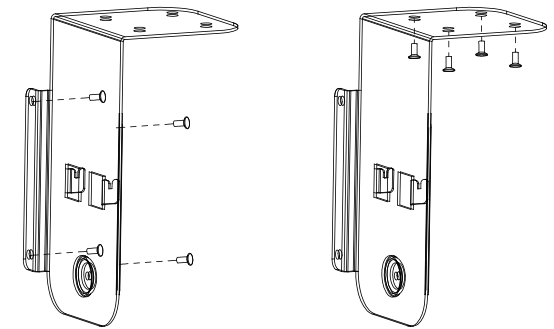
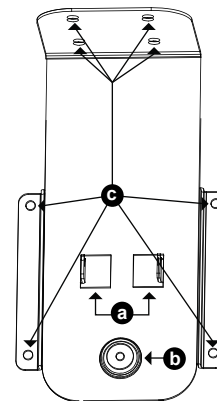

The safe can be mounted from the left or right with the included mounting bracket.

Use proper drill tools and mounting hardware for the type of surface you are mounting the safe too. Included screws are designed to be used on wood surfaces.

1. Open the safe with the pin code or key.
2. Unscrew the thumbscrews located on the inside of the safe.
3. Remove the bracket by sliding it down and off of the safe.
4. Use the wall mounting holes on the side or top of the mounting bracket to mark the desired mounting location.
5. Use appropriate mounting hardware to screw the bracket into desired location.
6. Slide the safe onto the bracket screw in thumbscrews located on the inside of the safe.
7. Close the safe

The safe is now ready to be used.

See reverse side for more information



1 YEAR LIMITED WARRANTY

Safe

BARSKA warrants this new safe to be free of original defects in material and/or workmanship under normal use for a period of twelve (12) months from the date product is received by purchaser. This warranty does not include damage caused by improper installation or maintenance. Damage from misuse, abuse, accident (such as dropping), normal wear and tear, fire, flood, or acts of nature. Damage from service or repairs other than those performed by BARSKA. Labor, cost and shipping charges for the removal and replacement of defective parts beyond the initial twelve-month warranty period. All transportation and shipping charges. Removing or altering the seal under any circumstances will automatically void the warranty.

This warranty is limited to original purchaser and is not transferable. This warranty applies only to products purchased in the United States.

Please email info@barska.com or call 1.888.666.6769 for Return Merchandise Number (RMA#) before any returns. The RMA number must appear on the outside of the shipping package. Product must be packed carefully and sturdily in its original packaging to prevent damage in transit and returned freight pre-paid to:

BARSKA OPTICS
Repair Department
855 Towne Center Drive
Pomona, CA 91767

Please include all of the following when returning BARSKA products for service and/or replacement:

1. Please write your complete details (Name, Address, Telephone #, E-mail address, RMA#, etc.)
2. Purchase receipt or Proof of Purchase. (Original/Copy)
3. A brief explanation of the defect.
4. A Check/Money Order of \$40.00 to cover inspection, shipping and handling.

*Please allow 6-8 weeks for delivery.

BARSKA will examine and test returned product and repair or replace defective part(s) or units with new part(s) or a new unit if necessary within the warranty period. Purchaser is required to remit \$40.00 to BARSKA for return shipping and handling at time product is returned. If repair is required after warranty period expiration, purchaser will be charged for replacement parts and return shipping.

BARSKA® Optics shall not be liable for any consequential, incidental and/or contingent damages whatsoever. We will not pay shipping, insurance or transportation charges from you to us, or any import fees, duties and or taxes. This warranty supersedes all previous BARSKA® Optics warranties.